

Note: Part numbers and standards' values may change. Consult LECO for the latest information.

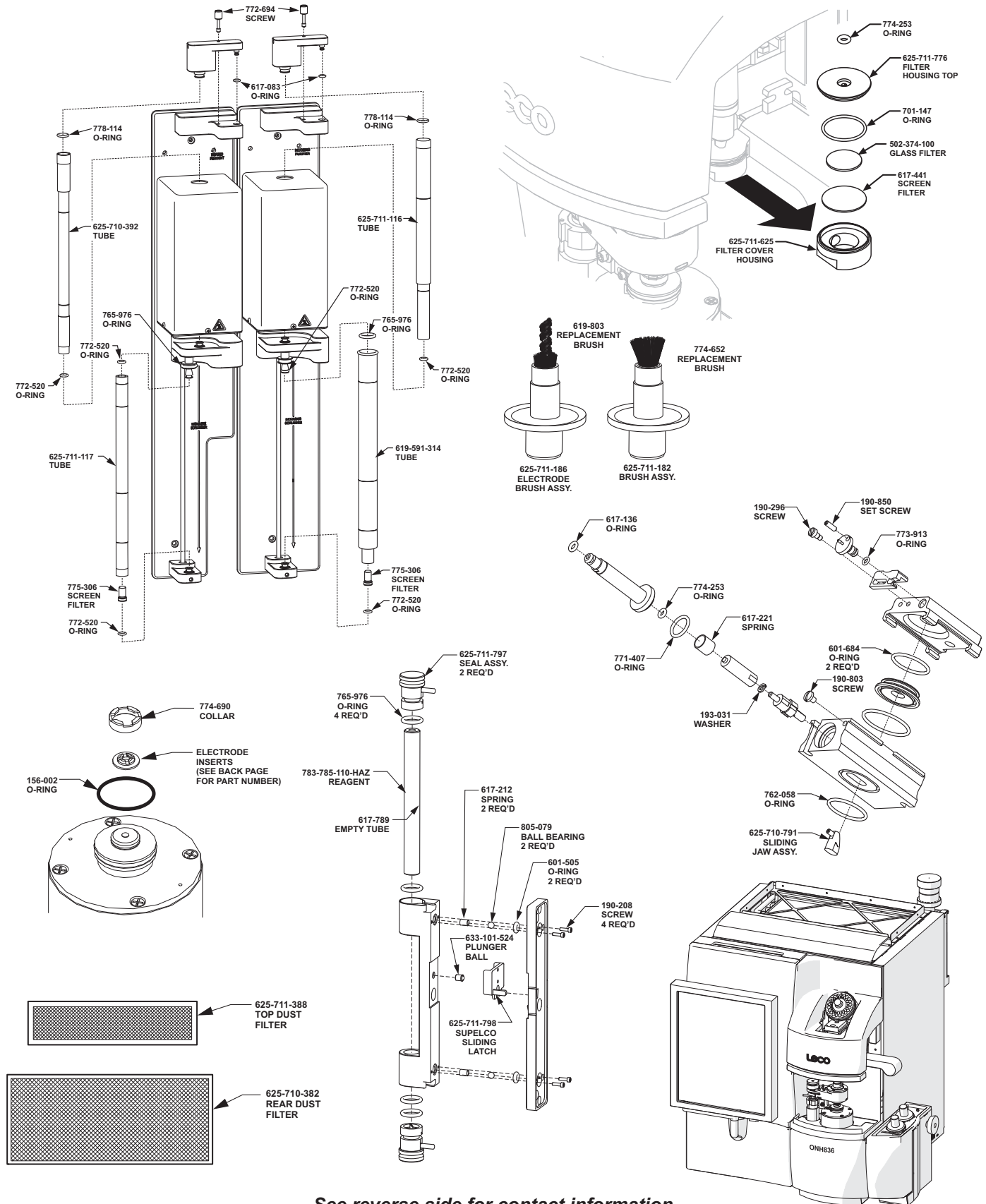

See reverse side for contact information

### FUSION SUPPLIES

- 776-247 Crucible (Standard), 1000
- 782-720 Crucible (Hi-Temp), 1000
- 501-598 Etchable Nibbled Nickel 100 g bottle
- 501-073 Graphite Powder 100 g bottle
- 502-040 Large Tin Capsule 100/bottle
- 617-866 Lower Electrode Assembly, requires 156-002 O-ring, includes: 617-862 Electrode, 774-690 Knurled Ring (Collar), Electrode Insert (see table at right)
- 502-822 Nickel Capsule 100/bottle
- 763-029 1.5 g Nickel Baskets 100/bottle
- 502-345 1.5 g Nickel Baskets Ultra High Purity 100/bottle
- 502-344 1.0 g Nickel Baskets Ultra High Purity 100/bottle
- 501-059 Small Tin Capsule 100/bottle
- 761-739 Tin Flux (Pellets), 0.5 g

- 619-591-724 Coolant
- 766-053 Crucible Tweezers
- 611-373 Electrode Insert Removal Tool
- 502-374-100 Filter Discs
- 775-306 Secondary Filter, 10 micron
- 502-023 Funnel
- 503-032 Glass Scoop
- 619-591-740 Medium Reagent Tube (Glass)
- 775-305 Sample Pan
- 760-138 Sample Tweezers (Straight)
- 625-711-260 Screen/Doser Stem Removal Tool
- 501-241 Vacuum Grease
- 767-473 Utility Funnel, Polypropylene
- 620-760 Vacuum Filter

\*Not part of 617-866 Assembly

### CATALYSTS AND REAGENTS

- 501-171-HAZ Anhydron 454 g (1 lb.) bottle
- 502-705 Copper Sticks 100 g ampule
- 502-878 Copper Sticks 100 g bottle
- 502-656 Copper Turnings 60 g bottle
- 502-190 Copper Oxide Wire 100 g bottle
- 501-081 Glass Wool 454 g (1 lb.) box
- 502-174-HAZ Lecosorb 500 g bottle, 20-30 mesh
- 502-176-HAZ Lecosorb 500 g bottle, 8-20 mesh
- 783-785-110-HAZ OMI Replacement Tube
- 501-608 Quartz Wool, 200 g

Electrode Insert	Crucible	Supports Automation
611-351-181	776-247	Yes
611-351-182	776-247	No
618-376	782-720	Yes
782-721	782-720	No

NOTE: Part numbers and standards' values may change. Consult LECO for latest information.

Please Note: Quartz Tubes are typically utilized for higher temperature applications (i.e. catalyst tubes). Glass reagent/filter tubes are designed for lower temperature applications. Glass tubes should not be used in place of quartz tubes.

### OPERATION ACCESSORIES

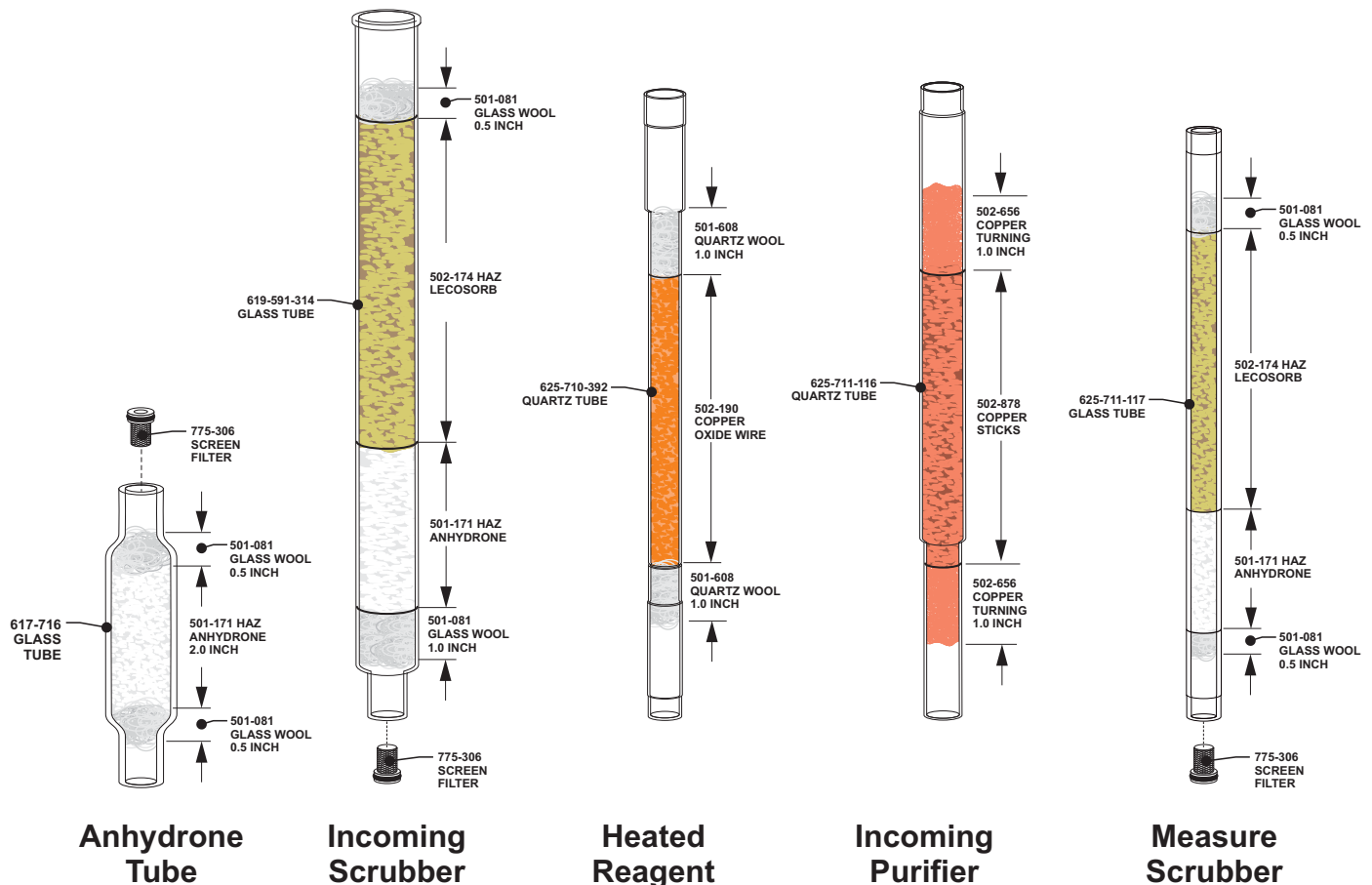

United States: 800-292-6141 • Canada: 800-268-0215 • Other Countries: 269-985-5496  
 info@leco.com • www.leco.com • ISO-9001:2008 HQ-Q-994 • © 2016 LECO Corporation